

# Installation Information

## LIPS<sup>®</sup> P103 SHORT STROKE LINEAR POSITION SENSOR

Output Option	Output Description:	Supply Voltage: $V_s$ (tolerance)	Load resistance: (include leads for 4 to 20mA O/Ps)
A	0.5 - 4.5V (ratiometric with supply)	+5V (4.5 - 5.5V)	$\geq 5k\Omega$
B	$\pm 5V$	$\pm 15V$ nom. ( $\pm 9 - 28V$ )	$\geq 5k\Omega$
C	0.5 - 9.5V	+24V nom. (13 - 28V)	$\geq 5k\Omega$
D	$\pm 10V$	$\pm 15V$ nom. ( $\pm 13.5 - 28V$ )	$\geq 5k\Omega$
E	4 - 20mA 2 wire Current Loop	+24V nom. (18 - 28V)	$\approx 0 - 300\Omega$ max. @24V ~ 1.2 to 6V across 300 $\Omega$ { $R_L$ max. = $(V_s - 18) / 20^{-3}$ }
F	4 - 20mA 3 wire Sink	+24V nom. (13 - 28V)	$\approx 0 - 950\Omega$ max. @24V ~ 3.8 to 19V across 950 $\Omega$ { $R_L$ max. = $(V_s - 5) / 20^{-3}$ }
G	0.5 - 4.5V	+24V nom. (9 - 28V)	$\geq 5k\Omega$
H	4 - 20mA 3 wire Source	+24V nom. (13 - 28V)	$\approx 0 - 300\Omega$ max. ~ 1.2 to 6V across 300 $\Omega$

Not all output options available - see product datasheet for full options list

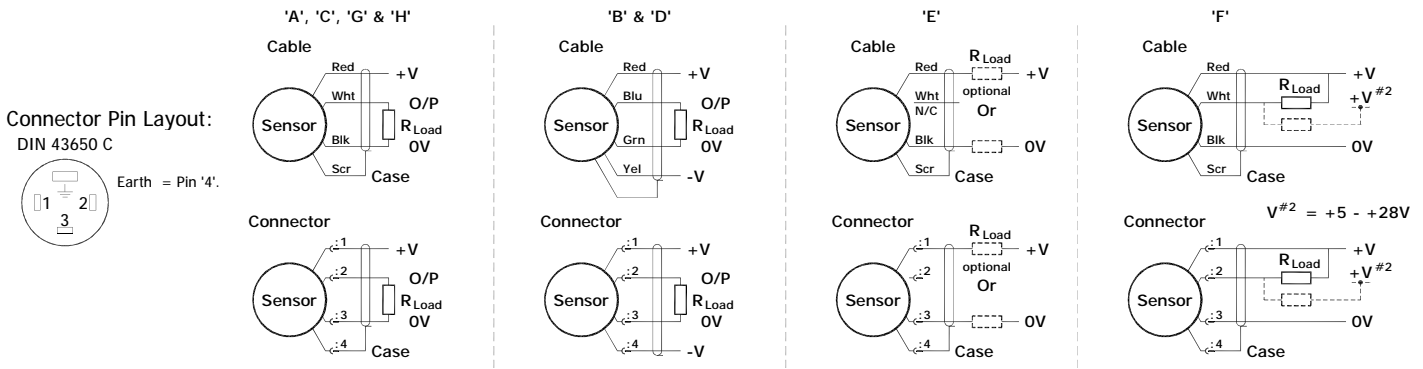

### Gain and Offset Adjustment: (Where accessible - Typically $\pm 10\%$ Min available)

To adjust the gain or offset use a small potentiometer adjuster or screwdriver 2mm across. Do not apply too much force on the potentiometers.

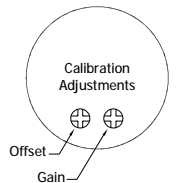

**Mechanical Mounting:** Flange mounted or by clamping the sensor body - body clamps are available, if not already ordered. The flange slots are 4.5 mm by 30 degrees wide on a 48 mm pitch.

**Output Characteristic:** Plunger extended, at start of normal travel, from mounting face by:  
 Standard body : 24.5 mm  
 Flanged body : 10 mm\*

\*Note: where ball end option is fitted add 5 mm.

The output increases as the plunger extends from the sensor body, the calibrated stroke is between 2 mm and 50 mm.

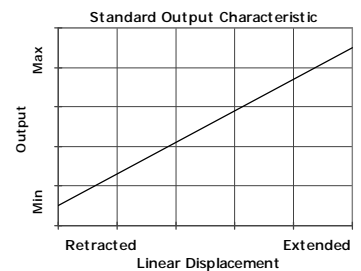

### Incorrect Connection Protection levels:-

- A **Not protected** – the sensor is **not** protected against either reverse polarity or over-voltage. The risk of damage should be minimal where the supply current is limited to less than 50mA.
- B & D Supply leads diode protected. Output must not be taken outside  $\pm 12V$ .
- C & G Supply leads diode protected. Output must not be taken outside 0 to 12V.
- E, F & H Protected against any misconnection within the rated voltage.